

# **FORNARA**

r u b i n e t t e r i e

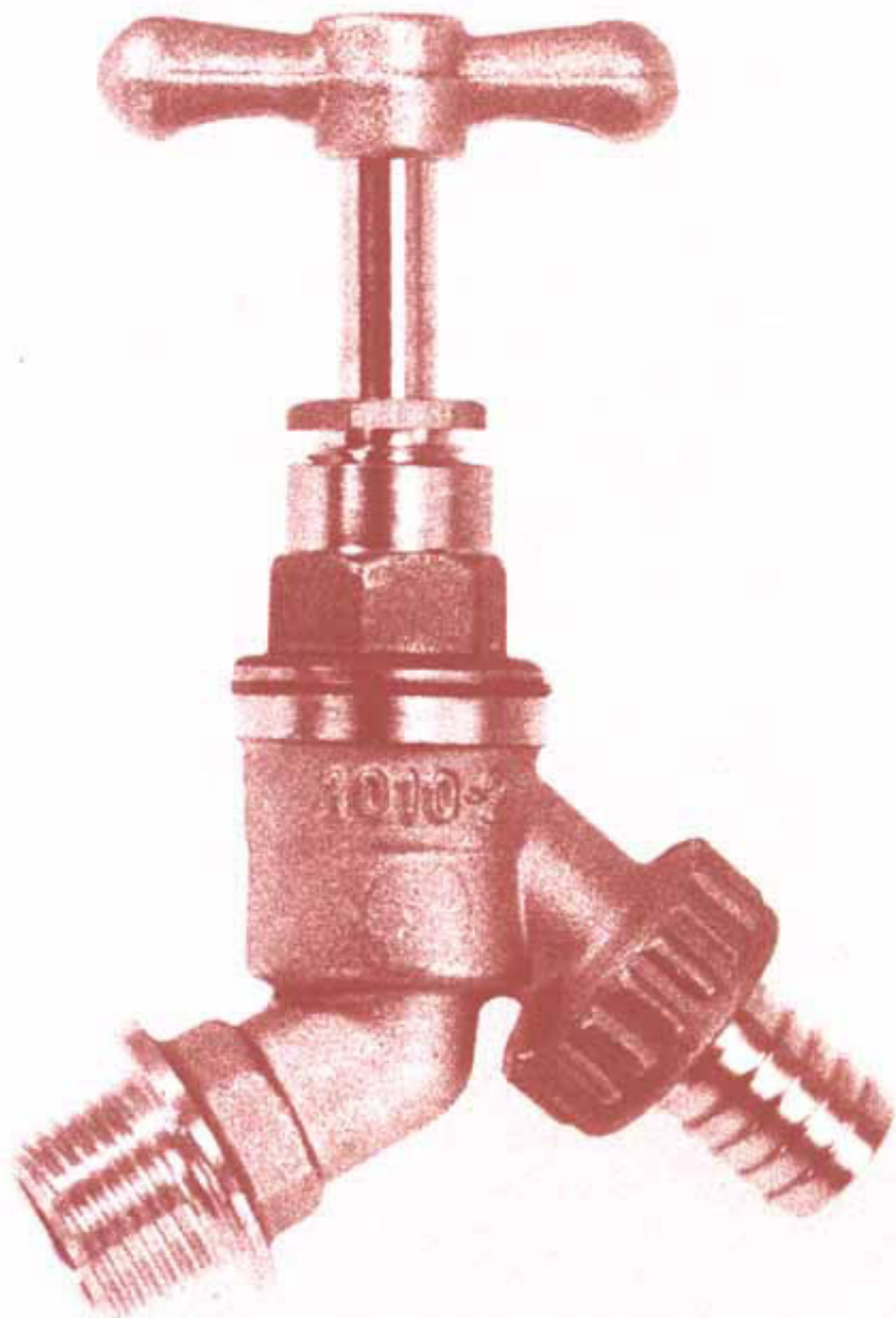

---

**VALVOLE E RUBINETTI**

---

**TAPS AND VALVES**

---



- **Valvola lavatrice diritta tipo leggero** lucida cromata con maniglie blu e rossa.
- *Straight washing machine tap light pattern polished chrome-plated with blue and red handles.*

- **Confezione: 100 pz./50 paia**
- *Packing: 100 pcs./50 prs.*

ART.	M
11215E-C--O	15 mm. X 3/4"
11315E-C--O	15 mm. X 3/4" <small>(paia/pairs)</small>



- **Valvola lavatrice diritta** lucida cromata con maniglie blu e rossa.
- *Straight washing machine tap polished chrome-plated with blue and red handles.*

- **Confezione: 100 pz./50 paia**
- *Packing: 100 pcs./50 prs.*

ART.	M
11015E-C--O	15 mm. X 3/4"
11115E-C--O	15 mm. X 3/4" <small>(paia/pairs)</small>



- **Valvola lavatrice angolo** lucida cromata con maniglie blu e rossa.
- *Angle washing machine tap polished chrome-plated with blue and red handles.*

- **Confezione: 100 pz./50 paia**
- *Packing: 100 pcs./50 prs.*

ART.	M
11415E-C--O	15 mm. X 3/4"
11515E-C--O	15 mm. X 3/4" <small>(paia/pairs)</small>



- **Valvola lavatrice a "T"** lucida cromata con maniglie blu e rossa.
- *Tee washing machine tap polished chrome-plated with blue and red handles.*

- **Confezione: 100 pz./50 paia**
- *Packing: 100 pcs./50 prs.*

ART.	M
11615E-C--O	15 mm. X 3/4"
11715E-C--O	15 mm. X 3/4" <small>(paia/pairs)</small>



■ **Valvola diritta di intercettazione per boiler**  
lucida cromata con maniglia nera.

■ *On-off straight valve polished chrome-plated with black handle.*

■ **Confezione: 100 pz.**

■ *Packing: 100 pcs.*

ART.	M
11815D-C--0	15 mm. X 1/2"

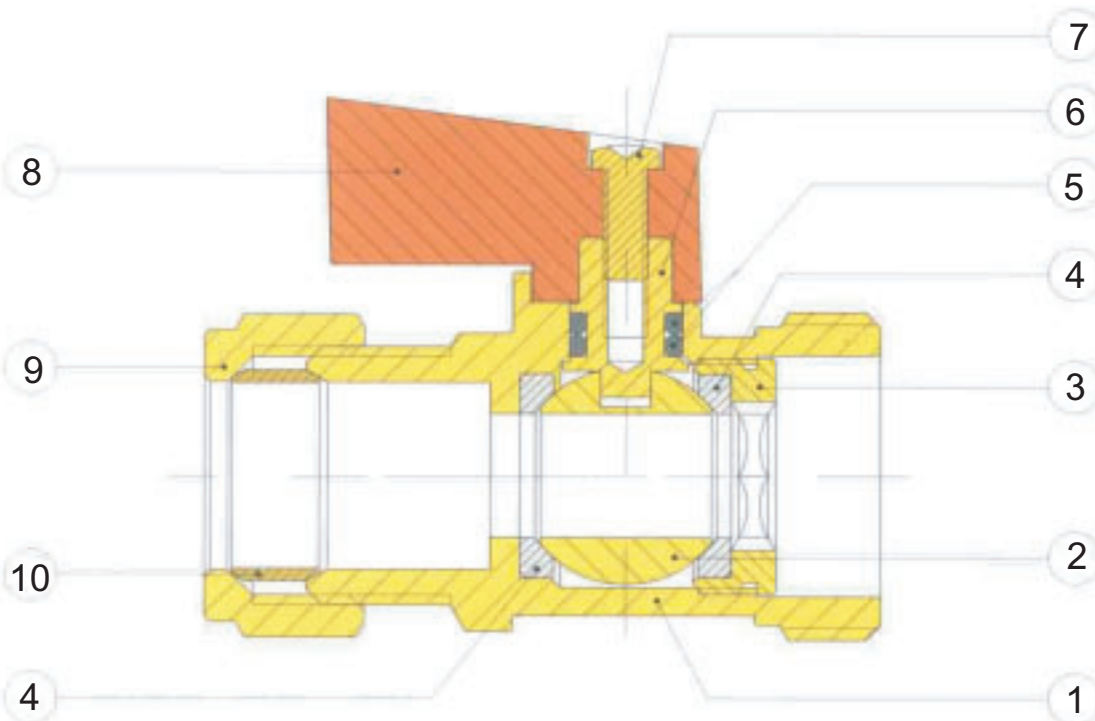

- 1: CORPO CW617N
- 2: SFERA
- 3: GHIERA
- 4: SEDE IN NBR
- 5: O.R. EP 70
- 6: ASTINA
- 7: VITE
- 8: MANIGLIA
- 9: CALOTTA
- 10: OGIVA

- 1: BRASS CW617N BODY
- 2: BALL
- 3: RING
- 4: RUBBER NBR SEAT
- 5: RUBBER EP 70 O-RING
- 6: ROD
- 7: SCREW
- 8: HANDLE
- 9: NUT
- 10: OLIVE



■ **Valvola a "T" di intercettazione per boiler**  
lucida cromata con maniglia nera.

■ *On-off tee valve polished chrome-plated with black handle.*

■ **Confezione: 100 pz.**

■ *Packing: 100 pcs.*

ART.	M
11915D-C--0	15 mm. X 1/2"



■ **Rubinetto arresto con attacco tubo rame sabbato giallo.**

■ *Stopcock for copper pipe sandblasted brass.*

■ **Confezione:** 15 mm. 50 pz.  
22 mm. 40 pz.  
28 mm. 30 pz.

■ **Packing:** 15 mm. 50 pcs.  
22 mm. 40 pcs.  
28 mm. 30 pcs.

ART.	M
2101515S--O	15 mm.
2102222S--O	22 mm.
2102828S--O	28 mm.

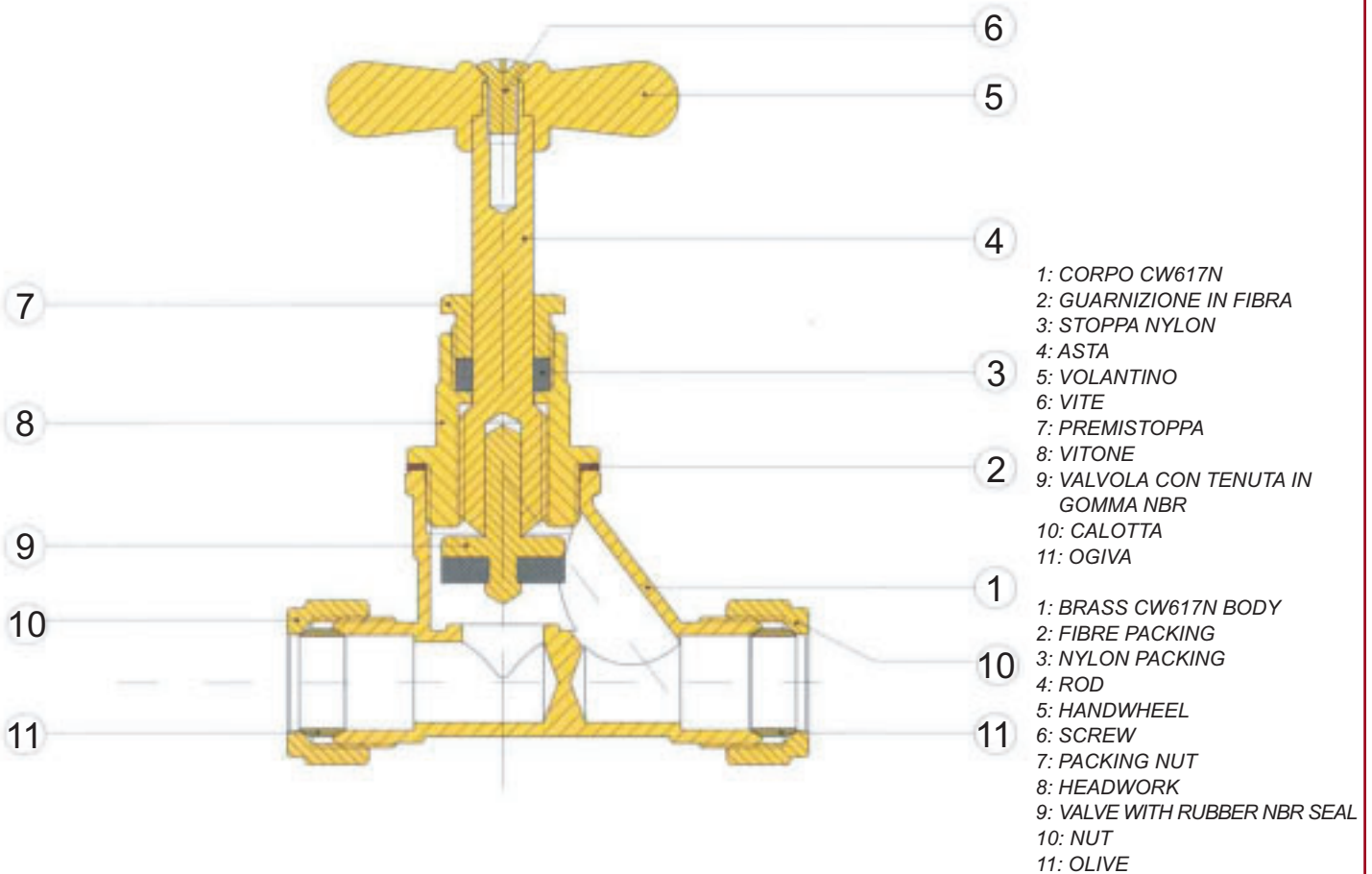

■ **Rubinetto arresto F/F sabbato giallo.**

■ *F/F Stopcock sandblasted brass.*

■ **Confezione:** 1/2" 50 pz.  
3/4" 40 pz.

■ **Packing:** 1/2" 50 pcs.  
3/4" 40 pcs.

ART.	M
211D-D-S--O	1/2"
211E-E-S--O	3/4"





- **Rubinetto arresto F/F con cappuccio, sabbiato giallo.**
- *F/F Stopcock with lockshield sandblasted brass.*

- **Confezione: 50 pz.**
- *Packing: 50 pcs.*

ART.	M
214D-D-S--O	1/2"



- **Rubinetto arresto con attacco tubo rame e tubo politene sabbiato giallo.**
- *Poly-Stopcock sandblasted brass.*

- **Confezione: 15 mm. e 20 mm 50 pz.  
22 mm. e 25 mm 40 pz.**
- *Packing: 15 mm. and 20 mm 50 pcs.  
22 mm. and 25 mm 40 pcs.*

ART.	M
2101520S--O	15mm.x20mm.
2101525S--O	15mm.x25mm.
2102020S--O	20mm.x20mm.
2102225S--O	22mm.x25mm.
2102525S--O	25mm.x25mm.



- **Rubinetto per gas lucido cromato.**
- *Restrictor elbow polished chrome-plated.*

- **Confezione: 100 pz.**
- *Packing: 100 pcs.*

ART.	M
230F-08C--O	1" x 8 mm.
230F-12C--O	1" x 12 mm.
230I-08C--O	2" x 8 mm.
230I-12C--O	2" x 12 mm.
230L-8C--O	4" x 8 mm.
230L-12C--O	4" x 12 mm.



- **Kit per rubinetto gas cromato.**
- *Kit for restrictor elbow chrome-plated.*

- **Confezione: 100 pz.**
- *Packing: 100 pcs.*

ART.	M
231B-08M--O	1" x 8 mm.



■ **Rubinetto portagomma**  
sabbiaato giallo.

■ *Hose union bibcock sandblasted*  
*brass.*

■ **Confezione:** 1/2" 50 pz.  
3/4" 40 pz.

■ **Packing:** 1/2" 50 pcs.  
3/4" 40 pcs.

ART.	M
200D---S--O	1/2"
200E---S--O	3/4"



■ **Rubinetto portagomma**  
"CR" con spurgo e  
ritegno sabbiaato giallo.

■ *Hose union bibcock "CR" with*  
*drain and check valve,*  
*sandblasted brass.*

■ **Confezione:** 100 pz.

■ **Packing:** 100 pcs.

ART.	M
201D---S--E	1/2"
201E---S--E	3/4"

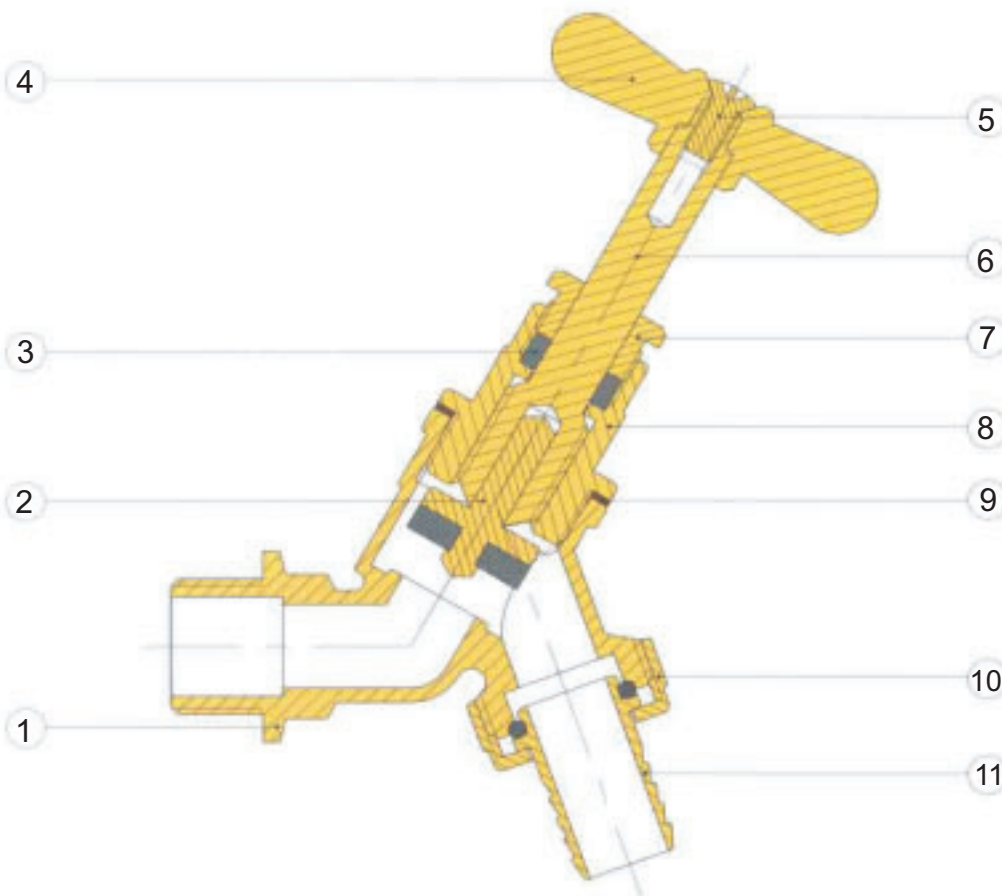

- 1: CORPO CW617N
- 2: VALVOLA CON TENUTA IN GOMMA NBR
- 3: STOPPA NYLON
- 4: VOLANTINO
- 5: VITE
- 6: ASTA
- 7: PREMISTOPPA
- 8: VITONE
- 9: GUARNIZIONE IN FIBRA
- 10: GIRELLO
- 11: PORTAGOMMA CON O.R.

- 1: BRASS CW617N BODY
- 2: VALVE WITH RUBBER NBR SEAL
- 3: NYLON PACKING
- 4: HANDWHEEL
- 5: SCREW
- 6: ROD
- 7: PACKING NUT
- 8: HEADWORK
- 9: FIBRE PACKING
- 10: HOSE UNION NUT
- 11: HOSE UNION TAIL WITH O.R.

## CARATTERISTICHE FLUIDODINAMICHE - FLUID-DYNAMICAL CHARACTERISTICS

**Art. 200---S--0**  
Rubinetto portagomma

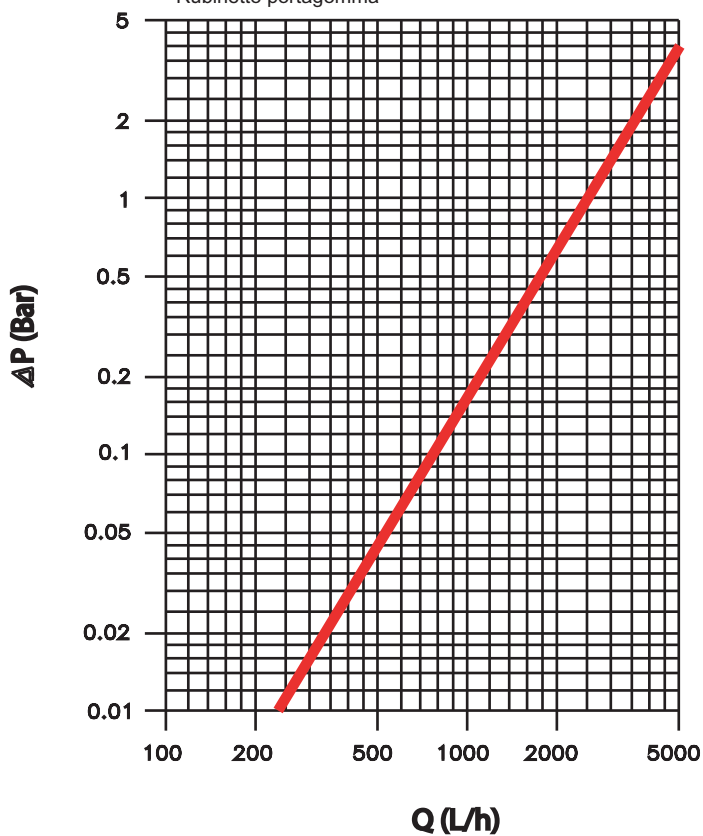

**Art. 201D---S--E**  
Rubinetto portagomma "CR" con spurgo e ritegno

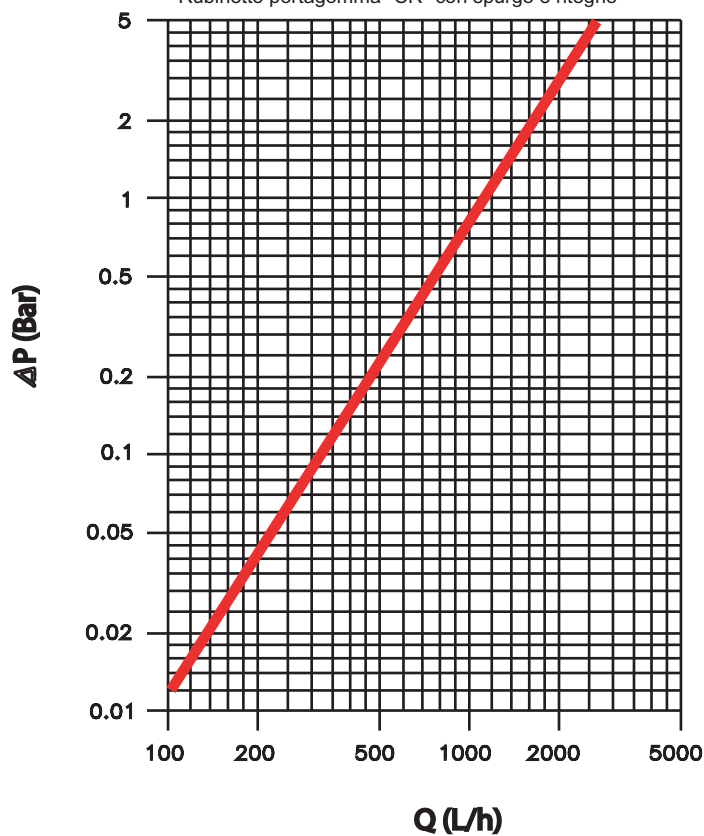

■ **Rubinetto da giardino**  
lucido giallo.

■ *Bibcock polished brass.*

■ **Confezione: 50 pz.**

■ *Packing: 50 pcs.*

ART.	M
202D---G--O	1/2"



■ **Girello e portagomma**  
sabbiaato giallo.

■ *Hose union nut and tail*  
*sandblasted brass.*

■ **Confezione: 1000 pz.**

■ *Packing: 1000 pcs.*

ART.	M
203D---S--O	1/2"
203E---S--O	3/4"



■ **Rubinetto spurgo tipo "A"**  
sabbato giallo.

■ *Drain Cock type "A"*  
*sandblasted brass.*

■ **Confezione:** 1/2" 250 pz.  
3/4" 100 pz.

■ **Packing:** 1/2" 250 pcs.  
3/4" 100 pcs.

ART.	M
220D-D-S--O	1/2"
220D-E-S--O	3/4"

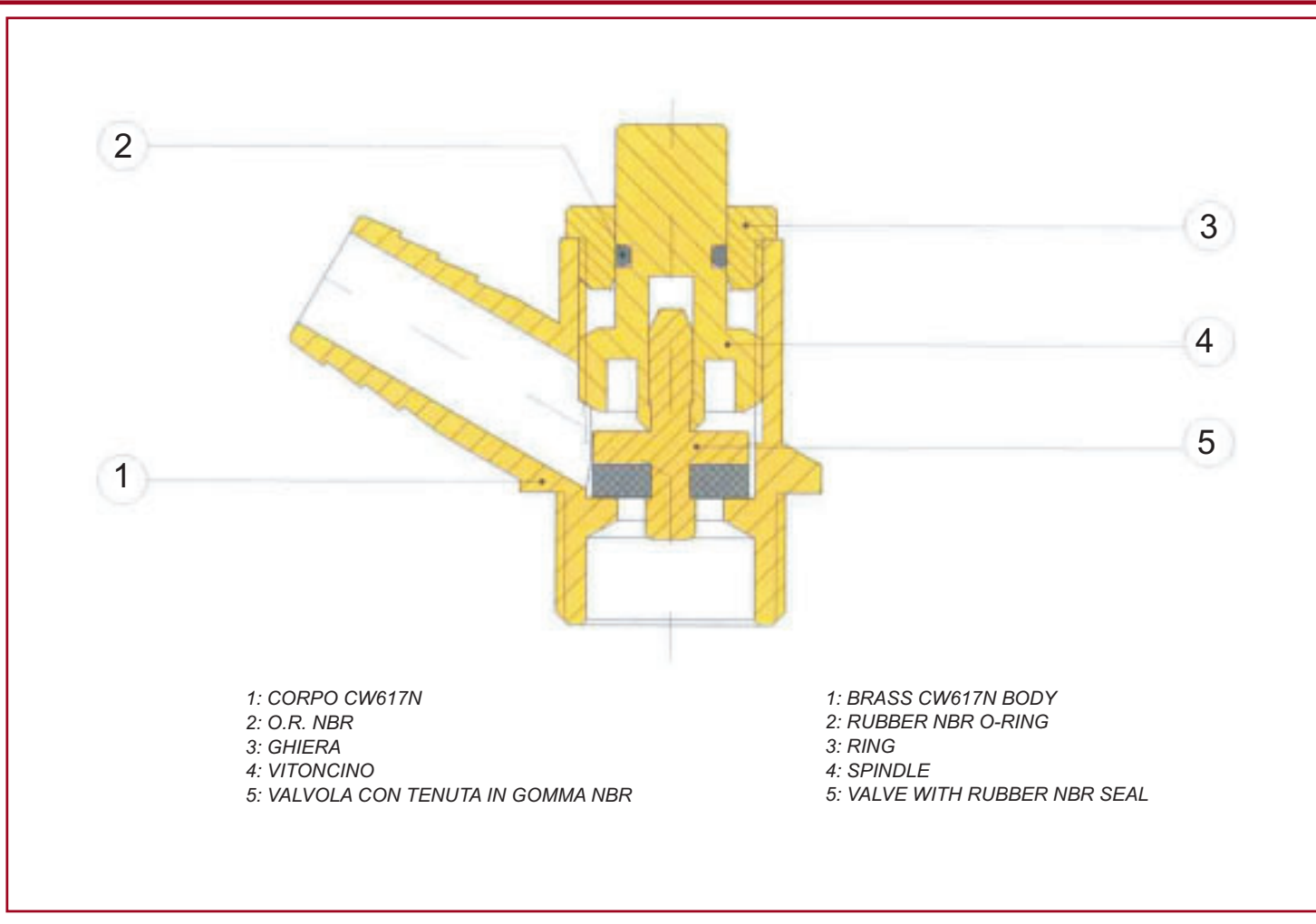

■ **Rubinetto spurgo tipo "A" capillare**  
sabbato giallo.

■ *Drain Cock type "A"*  
*sandblasted brass.*

■ **Confezione:** 250 pz.

■ **Packing:** 250 pcs.

ART.	M
220D-15S--O	15 mm.





■ **Rubinetto spurgo tipo "A"**  
con cappuccio, sabbiato giallo.

■ *Drain cock type "A" with  
lockshield, sandblasted brass.*

■ **Confezione: 250 pz.**

■ *Packing: 250 pcs.*

ART.	M
224D-D-S--O	1/2"



■ **Rubinetto spurgo tipo "C"**  
sabbiato giallo.

■ *Drain Cock type "C"  
sandblasted brass.*

■ **Confezione: 400 pz.**

■ *Packing: 400 pcs.*

ART.	M
222D-15S--O	15 mm.

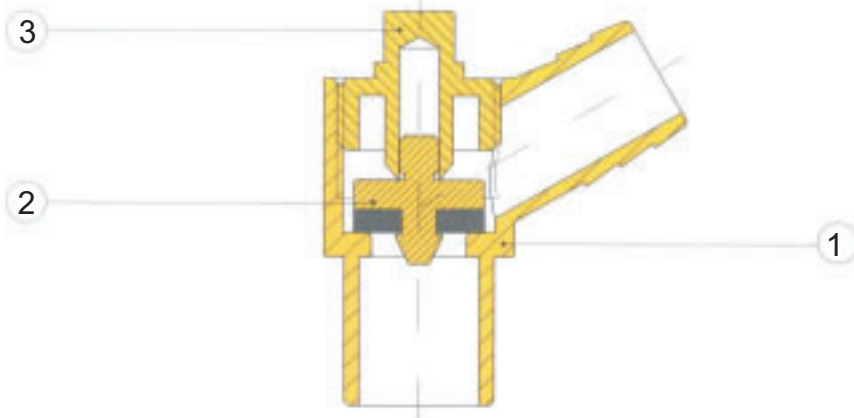

1: CORPO CW617N  
2: VALVOLA CON TENUTA IN GOMMA NBR  
3: VITONCINO

1: BRASS CW617N BODY  
2: VALVE WITH RUBBER NBR SEAL  
3: SPINDLE



■ **Rubinetto spurgo tipo "B"**  
sabbiato giallo.

■ *Drain Cock type "B"  
sandblasted brass.*

■ **Confezione: 400 pz.**

■ *Packing: 400 pcs.*

ART.	M
222D-D-S--O	1/2"



■ **Rubinetto spurgo radiatore**  
sabbato giallo.

■ *Drain Cock Adaptor*  
*sandblasted brass.*

■ **Confezione: 150 pz.**

■ *Packing: 150 pcs.*

ART.	M
2231515S--O	15mm.x15mm.



■ **Valvola antincendio**  
lucida gialla.

■ *Firevalve polished brass.*

■ **Confezione: 100 pz.**

■ *Packing: 100 pcs.*

ART.	M
310C-C-G--O	3/8" x 3/8"



■ **Valvola doppia ritegno "CR"**  
lucida cromata.

■ *Double check valve "CR"*  
*polished chrome-plated.*

■ **Confezione: 100 pz.**

■ *Packing: 100 pcs.*

ART.	M
3301515C--E	15 mm.
3302222C--E	22 mm.

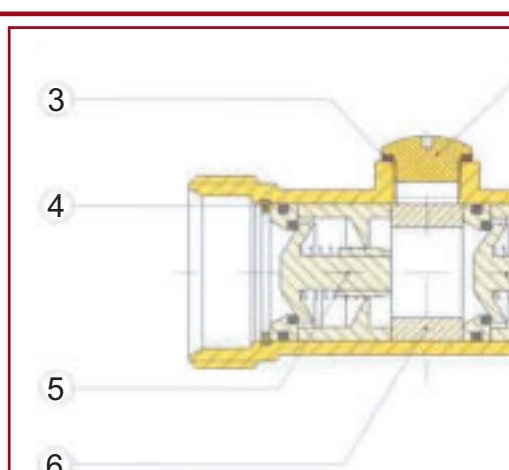

- 1: CORPO CW602N
- 2: VITE
- 3: GUARNIZIONE IN FIBRA
- 4: SEEGER
- 5: RITEGNO
- 6: DISTANZIALE

- 1: BRASS CW602N BODY
- 2: SCREW
- 3: FIBRE PACKING
- 4: CIRCLIP
- 5: CHECK VALVE
- 6: SPACER

## ■ I seguenti articoli sono disponibili anche nella finitura cromata:

■ *Following items are available with chrome-plated finishing too:*

ART.	ART.	ART.	ART.
200D---R--0	200E---R--0	202D---C--0	203D---R--0

## ■ I seguenti articoli sono disponibili anche nella finitura gialla:

■ *Following items are available with brass finishing too:*

ART.	ART.	ART.	ART.	ART.	ART.
230F-08G--0	230F-12G--0	230I-08G--0	230I-12G--0	230L-08G--0	230L-12G--0

## ■ CONDIZIONI DI VENDITA

I termini di consegna hanno carattere puramente indicativo: eventuali ritardi non possono dar luogo alla risoluzione, anche parziale del contratto.

Ordini ed impegni assunti dai ns. rappresentanti sono considerati validi solo dopo la nostra conferma.

I nostri imballaggi vengono eseguiti con la massima cura; tuttavia la merce viaggia a rischio e pericolo del committente.

Qualsiasi reclamo dovrà pervenirci per iscritto entro 30 giorni dal ricevimento della merce. Gli articoli difettosi saranno sostituiti gratuitamente se resi al nostro magazzino entro 2 mesi dalla data di consegna della merce.

La nostra garanzia per difetti nascosti è di un anno.

I pagamenti dovranno essere effettuati alle condizioni indicate in fattura. In ogni caso la merce fornita rimane di nostra proprietà finché non sia stato integralmente pagato il prezzo corrispondente. In caso di ritardato pagamento verranno addebitati gli interessi commerciali.

Per ogni controversia è competente il Foro di Novara.

## ■ SALES CONDITIONS

*Delivery terms are an indication only. Any delay shall not entitle customers to claim damages or to cancel the contract.*

*Orders taken by our agents are valid only after our confirmation.*

*Our products are packed with the utmost care; anyway goods are transported at customer's own risk.*

*Complaints must be advised, by letter, within 30 days from receipt of goods. Faulty items will be replaced free of charges, if returned to our warehouse within 2 months from goods delivery date.*

*Our guarantee for concealed defects is 1 year.*

*Payments must be made as per terms stated on the invoice. In any case goods remain property of seller until full payment is made.*

*In case of delayed payment, interests will be charged.*

*For any complaints the relevant authority is the Court of Novara.*

## ■ Il presente catalogo ha scopo illustrativo. Ci riserviamo il diritto di apportare variazioni tecniche da noi considerate necessarie per il miglioramento della qualità e funzionalità dei nostri articoli.

■ *This catalogue has illustrative purpose. We reserve ourselves the right to make any change in shape or design we consider necessary to improve the quality and functionality of our articles.*